

SPECIFICATION

MODEL : VIR35160G-3MASDN-P-Ø14

1. Focal Length : 3.5 ~ 16.0 mm
2. Back Focal Length : 6.15 ~ 16.11 mm
3. Optical Distortion : 1/2.7" CMOS -43.22 ~ -2.14%
1/2.8" CMOS -41.25 ~ -2.09%
1/3" -35.64 ~ -1.87%
1/4" -17.71 ~ -1.03%
4. Aperture Ratio : 1.2 ~ 360
5. Max. Image Format : 1/2.7" CMOS 5.8(H) x 3.2(V) mm (Ø6.61mm)
1/2.8" CMOS 5.6(H) x 3.8(V) mm (Ø6.4mm)
1/3" CCD 4.9(H) x 3.69(V) mm (Ø6.13mm)
1/4" CCD 3.6(H) x 2.7(V) mm (Ø4.5mm)
6. Operation : Iris / Auto Iris , Focus / Manual
7. Angle of View : (1/2.7" CMOS) (D)110.9° ~ 28.2° /(H)91.6° ~ 24.5° /(V) 47.6° ~ 13.8°
(1/2.8" CMOS) (D)108.1° ~ 27.6° /(H)80.8° ~ 22.1° /(V) 57.9° ~ 16.5°
(1/3" CCD) (D)100.0° ~ 26.1° /(H)75.4° ~ 20.8° /(V) 54.9° ~ 15.7°
(1/4" CCD) (D)69.4° ~ 19.4° /(H)54.2° ~ 15.5° /(V) 39.9° ~ 11.6°
8. Lens Construction : 8 Components 8 Elements & 1 Compensation Glass (1.1T)
(Including 1 Aspherical Lens Element)
9. Weight : 28g

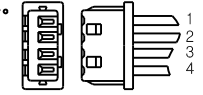
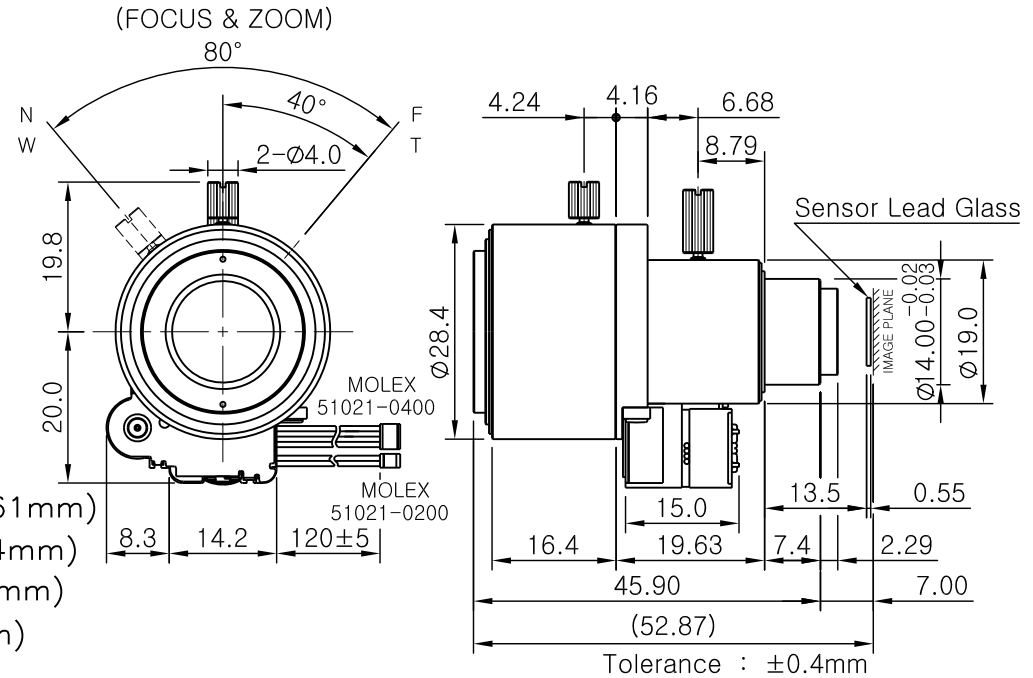

IRIS MOTOR PIN NUMBER

1	WHITE	+	CONTROL	3.5V-5V
2	BLACK	-	COIL (465Ω)	/20°C
3	RED	+	DRIVE	3.5V-5V
4	GREEN	-	COIL (190Ω)	/20°C

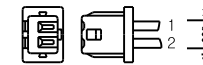

IR CUT MOTOR PIN NUMBER

1	YELLOW	±	DRIVE	IR Cut Filter
2	BROWN	±	COIL (190Ω)	IN→OUT
				3.5V~5V
				OUT→IN
				-5V~-3.5V

DAIWON OPTICAL CO., LTD.