

HF1616V DN P

Fixed Focal Length Lens for 1-Type 8Mega-Pixel Day & Night CCTV Camera

【 Specifications 】

Image Format	φ16mm	Operation	Focus : Manual
Applicable Camera	for 1 & 2/3 , 1/1.8 , 1/2-Type 8Mega Pixel Day&Night CCTV Camera	Iris Drive Motor	Iris : P-Iris Stepping Motor (Bi-Polor Type) Rated voltage : DC4V±1V Phase Resistance : 48Ω
Focal Length	16mm	Temperature Range	-10°C ~ +50°C (Operation) (Without condensation)
Max. Relative Aperture	1 : 1.6	Back Focal Length	14.9mm (in air)
Iris Range	F1.6 ~ F16	Flange Back (F.f)	17.526mm (in air)
Angle of View (H×V)	< When 1-Type Camera use > 23.7°× 13.7° (16:9) / 21.9°× 16.6° (4:3)	Mount	C Mount (Adjustable Lens Position)
Min. Object Distance	0.8m (From Front Lens)	Filter Size	M43×0.5mm
Object Dimensions at M.O.D. (HxV)	< When 1-Type Camera use > 36cm× 20cm (16:9) / 33cm× 25cm (4:3)	Weight	Approx. 250g

【 Dimension 】

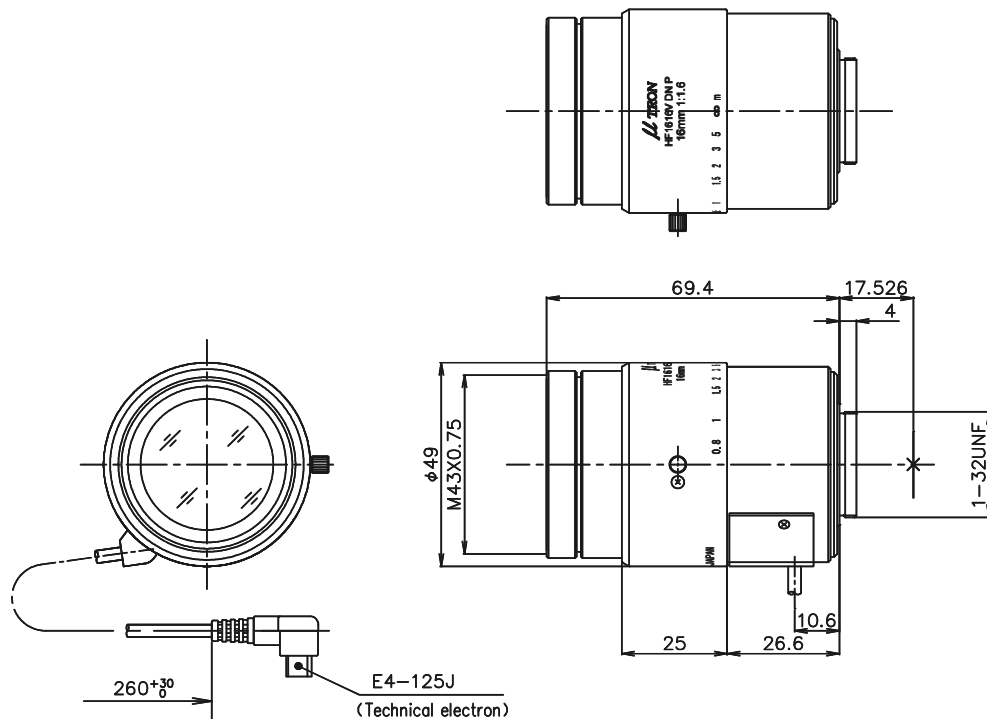

【 Wiring Diagram 】

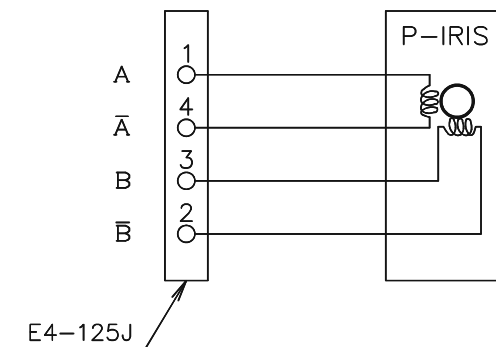

PIN	STEP PHASE	Close		Open	
		1	2	3	4
1	A	H	L	L	H
4	Ā	L	H	H	L
3	B	H	H	L	L
2	B̄	L	L	H	H