

HF2516V DN P

Fixed Focal Length Lens for 1-Type 8Mega-Pixel Day & Night CCTV Camera

CONFIDENTIAL

【 Specifications 】

Image Format	φ16mm	Operation	Focus : Manual
Applicable Camera	for 1 & 2/3 , 1/1.8 , 1/2-Type 8Mega Pixel Day&Night CCTV Camera	Iris Drive Motor	Iris : P-Iris Stepping Motor (Bi-Polar Type) Rated voltage : DC4V±1V Phase Resistance : 48Ω
Focal Length	25mm	Temperature Range	-10°C ~ +50°C (Operation) (Without condensation)
Max. Relative Aperture	1 : 1.6	Back Focal Length	14.7mm (in air)
Iris Range	F1.6 ~ F16	Flange Back (F.f)	17.526mm (in air)
Angle of View (H×V)	< When 1-Type Camera use > 28.2° × 21.2°	Mount	C Mount (Adjustable Lens Position)
Min. Object Distance	1.0m (From Front Lens)	Filter Size	M43×0.75mm
Object Dimensions at M.O.D. (HxV)	51.8cm × 38.6cm	Weight	Approx. 250g

【 Dimension 】

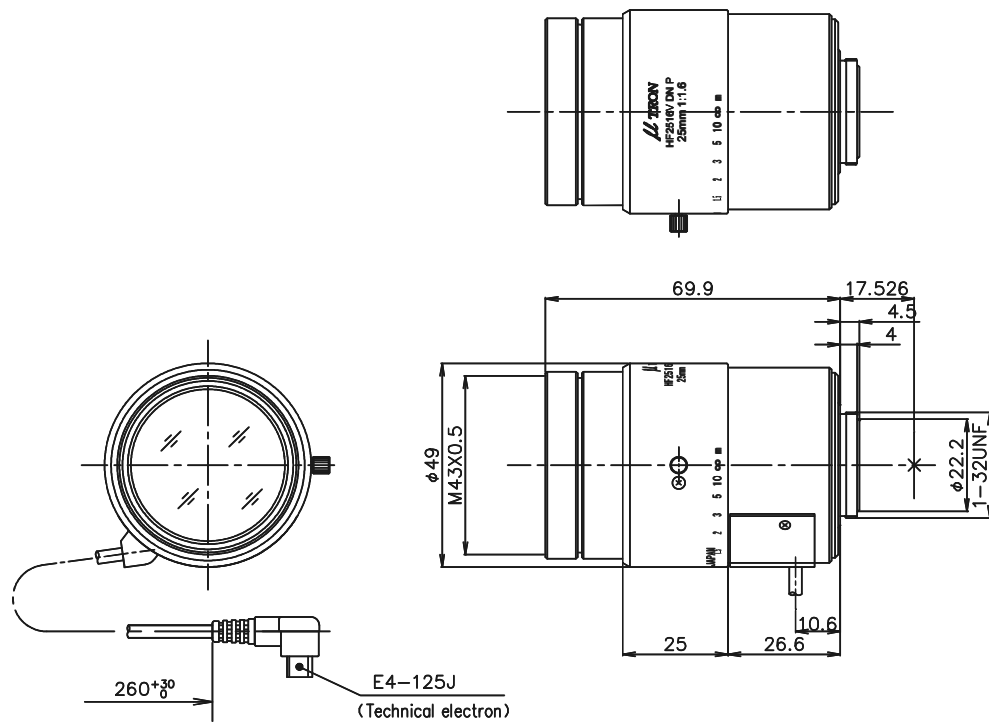

【 Wiring Diagram 】

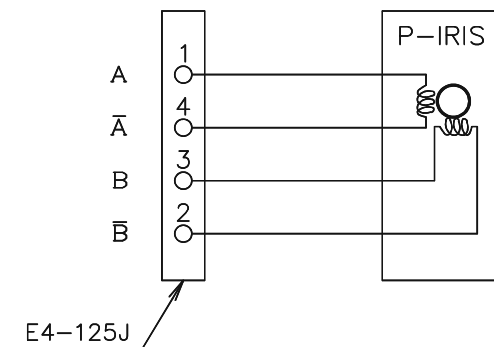

PIN	STEP PHASE	Close →		← Open	
		1	2	3	4
1	A	H	L	L	H
4	\bar{A}	L	H	H	L
3	B	H	H	L	L
2	\bar{B}	L	L	H	H