

# HF3516V DN P

Fixed Focal Length Lens for 1-Type 8Mega-Pixel Day & Night CCTV Camera

CONFIDENTIAL

## 【 Specifications 】

Image Format	φ16mm	Operation	Focus : Manual
Applicable Camera	for 1 & 2/3 , 1/1.8 , 1/2-Type 8Mega Pixel Day&Night CCTV Camera	Iris Drive Motor	Iris : P-Iris Stepping Motor (Bi-Polor Type) Rated voltage : DC4V±1V Phase Resistance : 48Ω
Focal Length	35mm	Temperature Range	-10°C ~ +50°C (Operation) ( Without condensation )
Max. Relative Aperture	1 : 1.6	Back Focal Length	15.0mm ( in air )
Iris Range	F1.6 ~ F16	Flange Back (F.f)	17.526mm ( in air )
Angle of View (H×V)	< When 1-Type Camera use > 20.8° × 15.6°	Mount	C Mount (Adjustable Lens Position)
Min. Object Distance	1.5m ( From Front Lens )	Filter Size	M43×0.75mm
Object Dimensions at M.O.D. (HxV)	< When 1-Type Camera use > 56.1cm × 41.9cm	Weight	Approx. 200g

## 【 Dimension 】

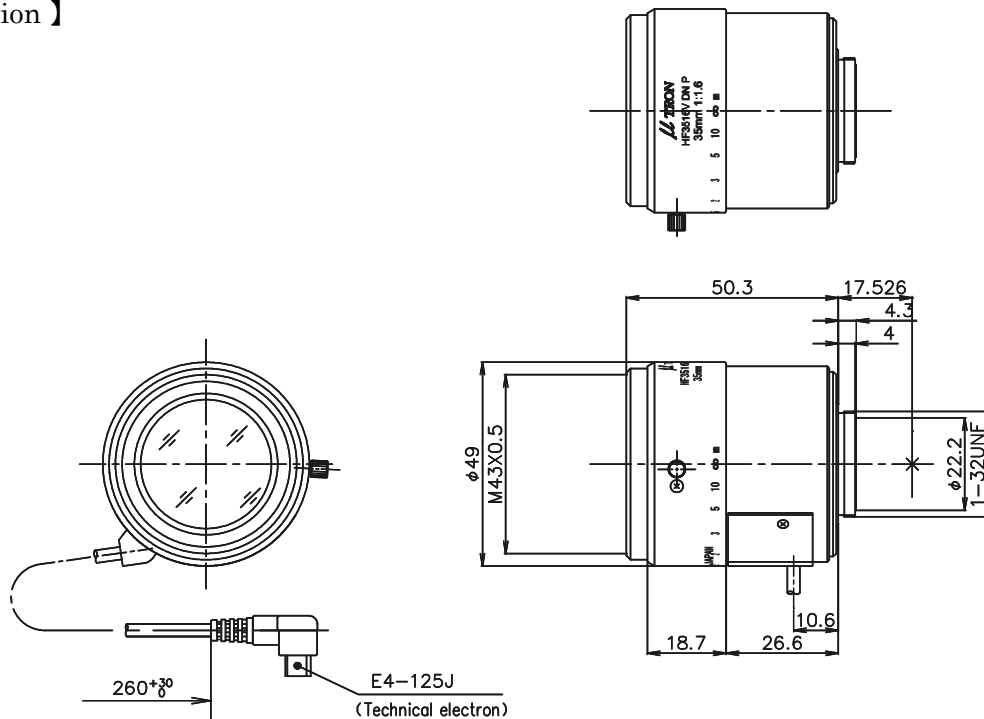

## 【 Wiring Diagram 】

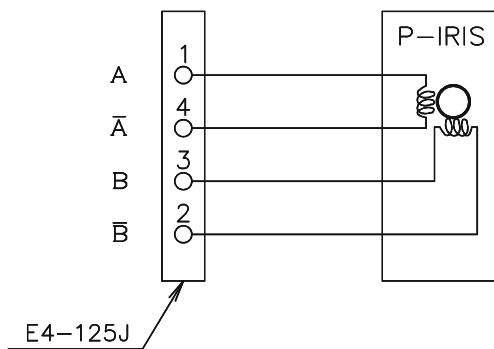

PIN	STEP PHASE	Close		Open	
		1	2	3	4
1	A	H	L	L	H
4	$\bar{A}$	L	H	H	L
3	B	H	H	L	L
2	$\bar{B}$	L	L	H	H