

Parameter of Lens

Model:	BLVD1150MP8-IR							
	Pixel	8 MegaPixel						
	Image format	1/1.7"						
	Focal length	11~50 (±5%) mm						
	Aperture	F1.4±10%						
	Mount	CS						
	Field Angle D×H×V(°) ±5%	°	1/1.7(4:3)		1/1.8(16:9)		1/2(4:3)	
			Wide	Tele	Wide	Tele	Wide	Tele
		D	47	10.9	44.2	10.4	39.5	9.4
		H	36.9	8.8	38.1	9	31.2	7.5
	V	27.2	6.6	21	5.1	23.1	5.6	
	Optical Distortion	-10.7~0.07% (1/1.7")						
	M. O. D.	1.5m						
	Chief Ray Angle	0.16° (Wide);0° (Tele)						
	Weight	267±5g						
Coating Range	400~900nm							
Flange BFL	12.5mm(in air)							
BFL	>8.26mm(in air)							
MBF	>6.95mm(in air)							
IR Correction	Yes							
Operation	Iris				DC			
	Focus				Manual			
	Zoom				Manual			
Operating temperature	-30°C~+70°C							

Size

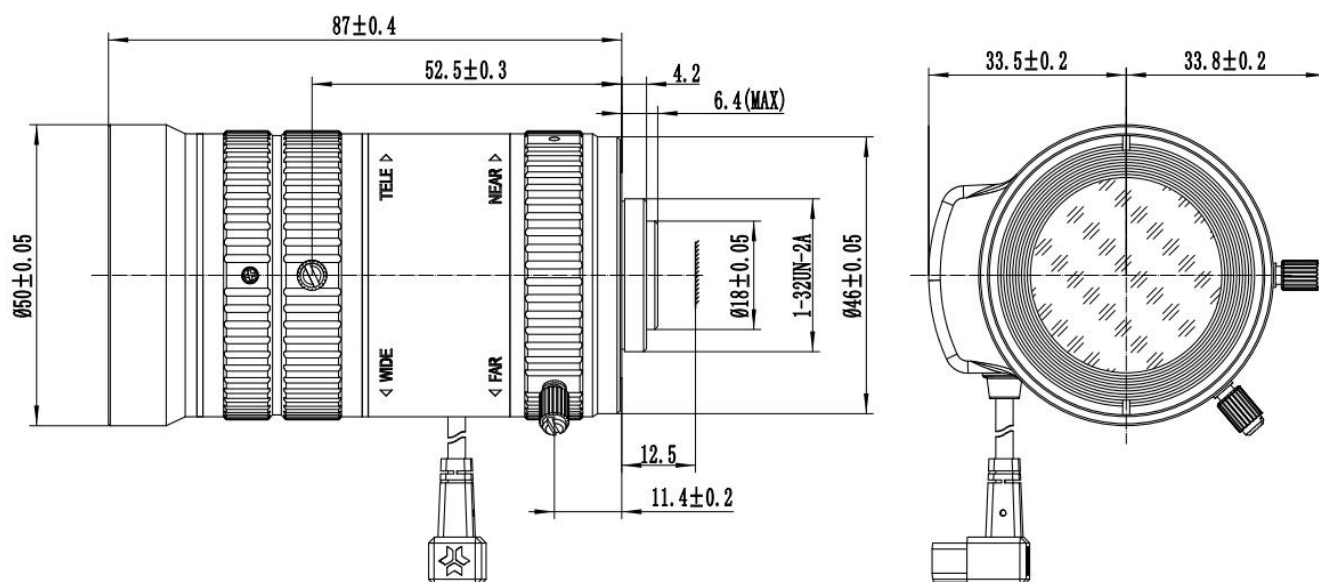

Test Standard			
Model:		BLVD1150MP8-IR	
Test Items		Test Content	
1	Resolution	Test Conditions	Plate Glass Thickness: 0.8 ± 0.2 mm, Project Distance: Short focus 2m, Tele 3m
		Center \geq	200 lp/mm
		$\Phi 8 \geq$	125 lp/mm
		Image Standard	The image should be clear.
2	Appearance	Inside Lens Barrel	60-40: 60 Scratch: The maximum scratch width is allowed to be 0.06mm, scratch length on the first surface < 1 mm, scratch length on other surface $< \Phi/4$. Scratch total length $< \Phi/2$. 40 Bright Spots: (the size of the bright spot is determined by the longest side)The maximum bright spot size is allowed to be 0.4mm, only one in the middle and edge regions. Two bright spots is allowed when the size ≤ 0.2 mm, and the distance must ≥ 1 mm;
		Outside Lens Barrel	The lens barrel has no obvious color difference, scratch, break, deformation; the glue is not allowed to overflow into the effective light path; no word drop, clear writing, the same font size, even spacing, etc;
		Rotation	Feel the rotation back and forth smoothly without jumping, stuck and abnormal sounds, etc
3	Auto Iris	Appearance	Cable and connector of iris have no obvious break, deformation, length of pins must be same. The following phenomena are not allowed: virtual welding of welding corners, false welding, falling off of the connector, loose and deformed structural parts, etc
		Actuation	The optical drive switching speed is slow and even, Do not act too fast, too slowly, or without action;
		Optical drive sensitivity	Use the camera to confirm the light sensitivity of the optical drive, and the response is sensitive and there is no time delay;

Reliability and Environmental Testing

Model:

BLVD1150MP8-IR

Test Items

Test Content

1 Temperature Cycling Test

Lens is placed on two cycles in the test temperature $(-30\pm 3)^{\circ}\text{C}$ for 1.5 hours and in $(70\pm 3)^{\circ}\text{C}$ for 3 hours separately. Then, the indicators are qualified after placing the lens at room temperature for 24 hours.

2 Damp heat test

Lens is placed in the test temperature $(70\pm 3)^{\circ}\text{C}$, humidity 85% RH for 48 hours. Then, the indicators are qualified after placing the lens at room temperature for 24 hours.

3 Drop Test

Lens drops from the height of $(1\pm 0.1\text{m})$ to the concrete ground. After the testing, the indicators are qualified.

4 Vibration Test

Lens vibrates 2h in sinusoidal wave under 1 mm of amplitude and 50Hz of frequency. After the testing, the indicators are qualified.

Packing Specification	
Model:	BLVD1150MP8-IR
<ol style="list-style-type: none">1. Stick label on the surface of lens after capped.2. Put the lens into the carton box.3. The unit will be packaged in a corrugated box.4. Seal the corrugated box with tape and mark the surface.	