

# MERCURY2 SERIES

## MER2-503-36U3M/C



- 5.0 Megapixels
- 2/3" global shutter CMOS sensor
- Ultra small, light and robust
- Compatible with GenICam™ and USB3 Vision®
- USB3.0 interface
- 2 programmable GPIOs

The MERCURY2 USB3.0 series (MER2-U3) camera is DAHENG IMAGING's new generation area scan industrial digital camera, featuring outstanding performance, compact design and extremely low noise.

The MER2-503-36U3M/C camera is a monochrome/color USB3 Vision camera with the Sony IMX264 CMOS sensor. Thanks to the compact design (29mm × 29mm × 29mm), robust metal housings and locking screw connectors, the MERCURY2 cameras can secure the reliability of cameras deployed in harsh environments. The MER2-503-36U3M/C camera has opto-isolated I/Os. The GPIOs give MER2-U3 cameras maximum flexibility to adapt to specific needs.

The MERCURY2 family cameras are especially suitable for machine vision applications such as industrial inspection, medical, scientific research, education, security and so on.

### Features

- Programmable ROI, increased frame rate with partial scan
- Gain, exposure and white balance programmable (white balance only for color models)
- Support auto gain, auto exposure and auto white balance (auto white balance only for color models)
- Four acquisition controls: Single frame acquisition / Continuous acquisition / Software trigger acquisition / External trigger acquisition
- Trigger mode: Frame Start /Frame Burst Start
- Support Timed exposure mode and TriggerWidth exposure mode
- Two exposure time modes: standard exposure time mode / minimal exposure time mode
- Support LUTs, storable user sets, Timer and Counter
- Support Decimation, Binning, Reverse X/Y, Digital Shift and Black Level
- Adjustable Gamma for optimizing the brightness of images
- Color models support Light source preset, Color Transformation Control and Saturation
- Monochrome models support Noise Reduction and Sharpness
- Support Remove Parameter Limit to expand the range of exposure, gain, white balance, and so on
- 16KB data storage area for saving algorithm coefficients and parameter configuration
- Compatible with GenICam™ and USB3 Vision®, support 3rd-party software such as HALCON, MERLIC and LabVIEW
- Optimized software package for 32/64bit Windows, and support Linux, Android, ARMv7 and ARMv8
- Multiple samples and easy-to-integrate SDKs for various programming tools
- Regulations: CE, RoHS, GenICam, USB3 Vision

## Performance Specifications

Model	MER2-503-36U3M/C
Interface	USB3.0
Resolution	2448(H) × 2048(V)
Frame rate	36 fps @ 2448 × 2048
Sensor	2/3", Sony IMX264 Global shutter CMOS
Pixel size	3.45 μm × 3.45 μm
Pixel Bit Depth	8bit, 10bit
Spectrum	Monochrome / Color
Exposure time	20μs~1s
Minimal exposure time	1μs~100μs

## Optical Specifications

Lens mount	C-Mount (standard), CS-Mount (optional)
------------	---

## Technical Drawing

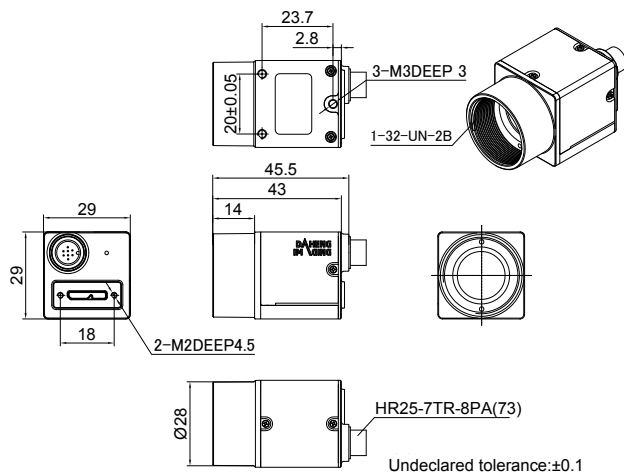

Units: mm

## Electrical Specifications

Power requirement	5 VDC via USB cable
I/Os	1 input / 1 output , 2 GPIOs
Data interface	Micro B with locked
Power consumption	<2.7W @5VDC

## Environmental Specifications

Operating temp.	0°C ~ +45°C
Storage temp.	-20°C ~ +70°C
Operating humidity	10% ~ 80%

## Mechanical Specifications

Weight	65g
Dimensions	29(W)×29(H)×29(L)mm, w/o connectors

## Spectral Response

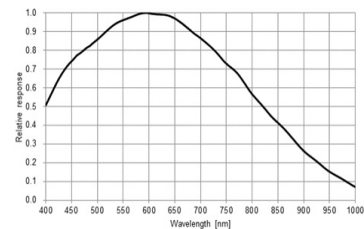

MER2-503-36U3M

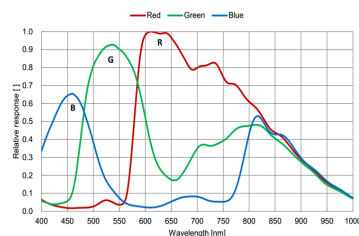

MER2-503-36U3C

China Daheng Group, Inc. Beijing Image Vision Technology Branch

12F Daheng Science & Technology Tower, No.3 Suzhou Street, Haidian District,

Beijing China, 100080

Tel: +86 10 82828878

E-mail: isales@daheng-imaging.com

For more information please visit: [www.daheng-imaging.com/en](http://www.daheng-imaging.com/en)

Specifications are subject to change without prior notice.

Copyright © 2022 China Daheng Group, Inc. Beijing Image Vision Technology Branch. All rights reserved.

July 26, 2022