

ME2P-2621-15U3M/C

MERCURY2 Plus Series 26.2MP CMOS USB3.0 Area Scan Camera



The ME2P-2621-15U3M/C camera is a monochrome/color USB3.0 Vision camera with the Gpixel GMAX0505 CMOS sensor. The ME2P-2621-15U3M/C camera has opto-isolated I/Os that adapt to specific needs. Four-side mounting holes provide maximum installation flexibility for ME2P-U3. Thanks to the extremely compact (36mm × 31mm × 38.8mm), robust metal housings and locking screw connectors, the MERCURY2 Plus cameras can secure the reliability of cameras deployed in harsh environments.

Applications

Suitable for machine vision applications such as industrial inspection, medical, scientific research, education, security and so on.

Spectral Response

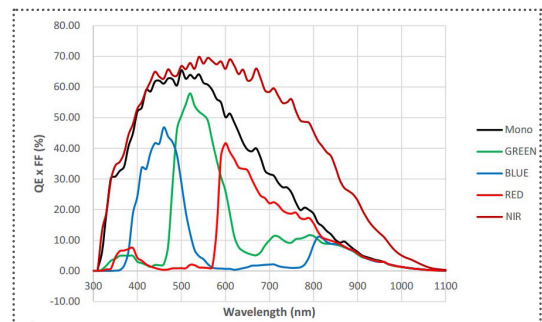

Features

- Trigger mode: Frame Start /Frame Burst Start
- Support Gamma, Binning, Decimation, Digital Shift
- Support Black Level, Auto Black Level
- Support Flat Field Correction and Static Defect Pixel Correction
- Color models support Light source preset, Color Transformation Control and Saturation
- Monochrome models support Noise Reduction and Sharpness
- Programmable LUTs and User Set Control
- Support Timer and Counter
- Support Remove Parameter Limit to expand the range of exposure, gain, and so on
- 16KB data storage area for saving algorithm coefficients and parameter configuration

Specifications

Model	ME2P-2621-15U3C	ME2P-2621-15U3M
Resolution	5120(H) × 5120(V)	
Sensor	GMAX0505 Global shutter CMOS	
Sensor Format	1.1"	
Pixel Size	2.5μm × 2.5μm	
Frame Rate	15.1 fps	
ADC	12 bit	
Pixel Bit Depth	8 bit, 12 bit	
Mono/Color	Color	Mono
Pixel Formats	Bayer GB8 / Bayer GB12	Mono8 / Mono12
SNR	36.18 dB	36.15 dB
Exposure Time	Standard: 11μs ~ 1s, Actual Steps: 1μs	
Gain	0dB ~ 16dB; Default: 0dB, Steps: 0.1dB	
Binning	1×1, 1×2, 1×4, 2×1, 2×2, 2×4, 4×1, 4×2, 4×4	
Decimation	Horizontal FPGA, Vertical Sensor: 1×1, 1×2, 1×4, 2×1, 2×2, 2×4, 4×1, 4×2, 4×4	
Synchronization	Hardware trigger, software trigger	
Acquisition Mode	Single frame, Continuous, Software trigger, Hardware trigger	
Reverse X/Y	Reverse X/Y	
I/O Interface	1 input and 1 output with opto-isolated, 2 programmable GPIOs	
Data Interface	USB3.0	
Power Supply	Power through USB3.0 interface	
Power Consumption	< 3.5 W @ 5 VDC	
Operating Temp.	0°C ~ +45°C	
Storage Temp.	-20°C ~ +70°C	
Operating Humidity	10% ~ 80%	
Lens Mount	C / CS	
Dimensions	36(W) × 31(H) × 38.8(L) mm (without lens adapter or connectors)	
Weight	66 g	
Software	3rd-party software such as HALCON, MERLIC and LabVIEW	
OS	32bit / 64bit Windows, Linux, Android, ARMv7, ARMv8	
Conformity	CE, RoHS, FCC, ICES, UKCA, USB3.0 Vision®, GenICam®	

I/O Interface



Pin	Definition	Core Color	Description
1	Line 0+	Green	Opto-isolated input +
2	GND	Blue	GPIO GND
3	Line 0-	Grey	Opto-isolated input -
4	NC	Purple	NC
5	Line 2	Orange	GPIO input/output
6	Line 3	Pink	GPIO input/output
7	Line 1-	White Green	Opto-isolated output -
8	Line 1+	White Blue	Opto-isolated output +

Technical Drawing

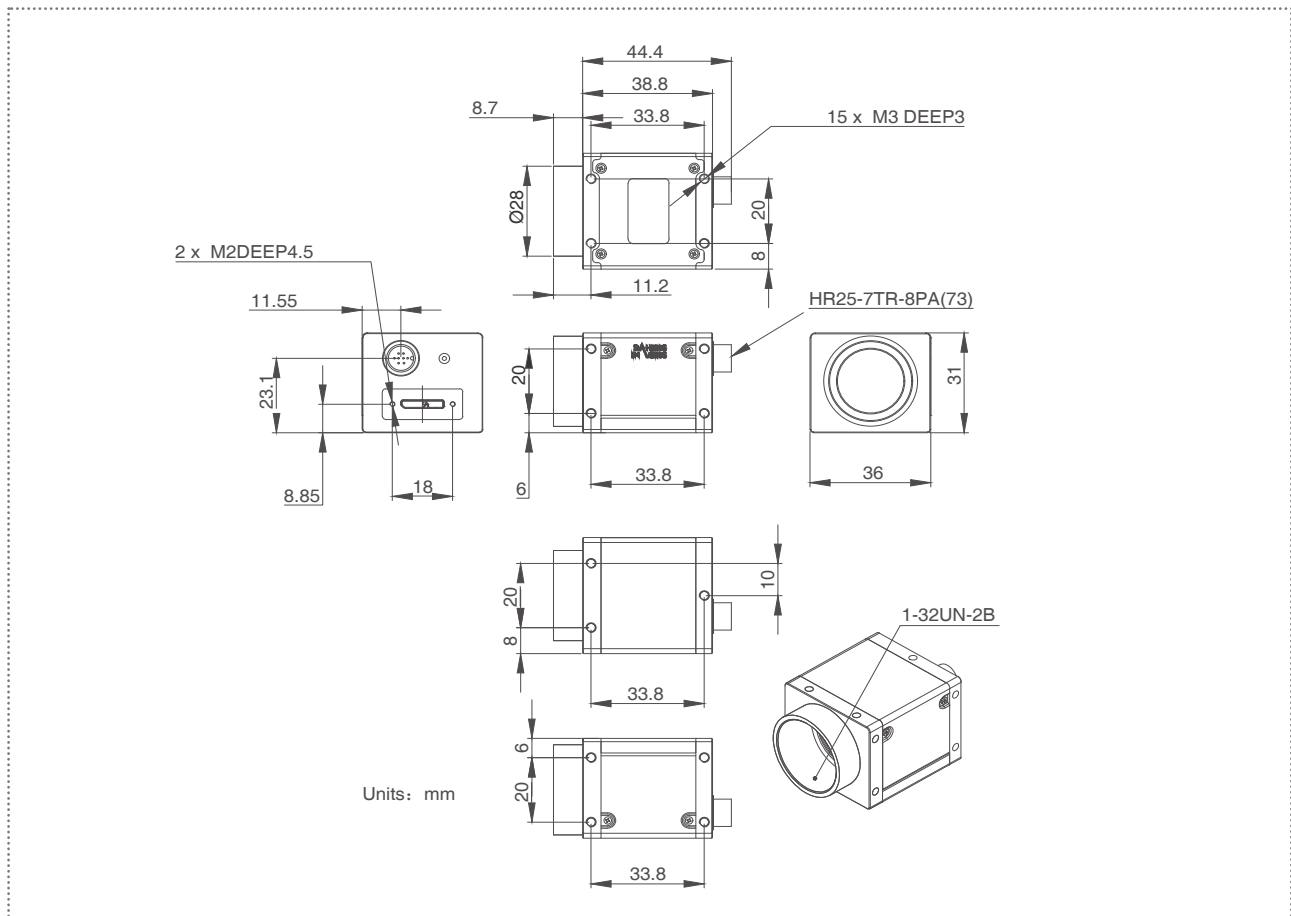

China Daheng Group, Inc. Beijing Image Vision Technology Branch

12F Daheng Science & Technology Tower, No.3 Suzhou Street, Haidian District, Beijing China, 100080

Tel: +86 10 82828878

E-mail: isales@daheng-imaging.com